



MODEL 7N SPRAY GUN

Binks Model 7N Gun is a rugged, light weight, hand held Spray Gun, for applying gel-coats and polyester resins. Catalyst is introduced to the material stream through the atomizing air as the resin flows from the Material Nozzle. Flow rate of the Gun varies up to 2 GPM depending on nozzle selection. The actual fluid output is controlled by nozzle orifice size and fluid pressure.

NOZZLE TYPES

Internal Mix—Low to high material volume, low air consumption.

External Mix—Low material volume, fine atomization.

Spray patterns are determined by the nozzle selection and vary somewhat depending on size, angle, nozzle orifice and output. External mix nozzle pattern cannot be changed because this gun does not have a side port control. However, its spray fan pattern can be rotated through 360° by loosening the Retaining Ring, and rotating the Nozzle Body, Item 1.

Faulty spray patterns can be caused by:

1. Foreign material in Air and/or Fluid Passages.
2. Viscosity too high for spraying. Air supply or pressure inadequate.
3. Worn or damaged Nozzle surfaces.
4. Gellation in Gun Head Air Passages.
5. Gun Head Check-Valve, Items 6, 7, 8 frozen.

GUN CLEANING

Submerging the Gun in solvent will not harm the Gun; however, it can adversely affect the Nozzle “O” Ring, Item 2. Submerging is poor practice because of the solvent residue that may cling to interior air passages. Clean solvent MUST be used if the Gun is to be submerged. The best practice is to remove the Air Nozzle and to flush solvent through the fluid passages. All Nozzles may be placed in solvent for washing. The Nozzle Orifice and angle passage ways are critical. Always wash and rinse with a clean solvent to prevent residue accumulation in the minute holes. NEVER use metal instruments for cleaning.

CHECK-VALVE CLEANING

A Check-Valve in the Head of the Gun prevents resin from backing up into Air/Catalyst Passage. However, resin build-up periodically may cause the Ball to freeze in the Head. To free Ball:

1. Remove Plug, Item 11, Fluid Needle Assembly, Item 16, and Packing Nut, Item 38.
2. Insert Wrench, Part No. 73-165, and turn counter-clockwise to remove Head, Item 5, and Check-Valve Components, Items 6, 7, and 8.
3. Clean as required and reassemble.

Exterior surfaces of Gun should be kept clean by wiping with a solvent-wet cloth.

RESIN PACKING

Packing take-up is accomplished by tightening Packing Nut, Item 38, with a wrench. Packing replacement is simple; proceed as follows:

1. Remove Fluid Control Screw, Item 17.
2. Remove Needle Assembly, Item 16.
3. Remove Packing Nut, Item 38, and old Packing, Item 37, from Cavity.
4. Insert new Packing in Cavity.
5. Reassemble items removed in (1), (2) and (3) above.
6. Set Packing, Item 37, by tightening Packing Nut, Item 38, until Needle movement, Item 16, is resisted, then loosen approximately 1/2-3/4 turn.

AIR LEAKS:

Through Gun Head

1. Leaky Air Valve, Item 28. Inspect, clean, or replace.
2. Air Valve Body, Item 30, not seated. Tighten.
3. Air Valve Body Gasket, Item 26, missing or damaged. Replace.
4. Damaged Seat surface in Gun Body, Item 22. Replace.

At Air Catalyst Valve, Item 28

1. Around Air Valve Stem, Item 29. Tighten or replace Packing, Item 31.
2. Damaged Air Valve Stem. Inspect and replace if necessary.
3. Damaged Seat surfaces. Attempt repair with PTFE tape. Replace if necessary.

In this part sheet, the words **WARNING**, **CAUTION** and **NOTE** are used to emphasize important safety information as follows:

WARNING

Hazards or unsafe practices which could result in severe personal injury, death or substantial property damage.

CAUTION

Hazards or unsafe practices which could result in minor personal injury, product or property damage.

NOTE

Important installation, operation or maintenance information.

WARNING

Read the following warnings before using this equipment.



READ THE MANUAL

Before operating finishing equipment, read and understand all safety, operation and maintenance information provided in the operation manual.



OPERATOR TRAINING

All personnel must be trained before operating finishing equipment.



EQUIPMENT MISUSE HAZARD

Equipment misuse can cause the equipment to rupture, malfunction, or start unexpectedly and result in serious injury.



LOCK OUT / TAG-OUT

Failure to de-energize, disconnect, lock out and tag-out all power sources before performing equipment maintenance could cause serious injury or death.



AUTOMATIC EQUIPMENT

Automatic equipment may start suddenly without warning.



PRESSURE RELIEF PROCEDURE

Always follow the pressure relief procedure in the equipment instruction manual.



KEEP EQUIPMENT GUARDS IN PLACE

Do not operate the equipment if the safety devices have been removed.



KNOW WHERE AND HOW TO SHUT OFF THE EQUIPMENT IN CASE OF AN EMERGENCY



WEAR SAFETY GLASSES

Failure to wear safety glasses with side shields could result in serious eye injury or blindness.



INSPECT THE EQUIPMENT DAILY

Inspect the equipment for worn or broken parts on a daily basis. Do not operate the equipment if you are uncertain about its condition.



NEVER MODIFY THE EQUIPMENT

Do not modify the equipment unless the manufacturer provides written approval.



NOISE HAZARD

You may be injured by loud noise. Hearing protection may be required when using this equipment.

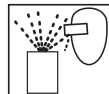

PROJECTILE HAZARD

You may be injured by venting liquids or gases that are released under pressure, or flying debris.



PINCH POINT HAZARD

Moving parts can crush and cut. Pinch points are basically any areas where there are moving parts.



STATIC CHARGE

Fluid may develop a static charge that must be dissipated through proper grounding of the equipment, objects to be sprayed and all other electrically conductive objects in the dispensing area. Improper grounding or sparks can cause a hazardous condition and result in fire, explosion or electric shock and other serious injury.



WEAR RESPIRATOR

Toxic fumes can cause serious injury or death if inhaled. Wear a respirator as recommended by the fluid and solvent manufacturer's Safety Data Sheet.



TOXIC FLUID & FUMES

Hazardous fluid or toxic fumes can cause serious injury or death if splashed in the eyes or on the skin, inhaled, injected or swallowed. LEARN and KNOW the specific hazards of the fluids you are using.



FIRE AND EXPLOSION HAZARD

Improper equipment grounding, poor ventilation, open flame or sparks can cause a hazardous condition and result in fire or explosion and serious injury.



MEDICAL ALERT

Any injury caused by high pressure liquid can be serious. If you are injured or even suspect an injury:

- Go to an emergency room immediately.
- Tell the doctor you suspect an injection injury.
- Show the doctor this medical information or the medical alert card provided with your airless spray equipment.
- Tell the doctor what kind of fluid you were spraying or dispensing.



GET IMMEDIATE MEDICAL ATTENTION

To prevent contact with the fluid, please note the following:

- Never point the gun/valve at anyone or any part of the body.
- Never put hand or fingers over the spray tip.
- Never attempt to stop or deflect fluid leaks with your hand, body, glove or rag.
- Always have the tip guard on the spray gun before spraying.
- Always ensure that the gun trigger safety operates before spraying.

IT IS THE RESPONSIBILITY OF THE EMPLOYER TO PROVIDE THIS INFORMATION TO THE OPERATOR OF THE EQUIPMENT. FOR FURTHER SAFETY INFORMATION REGARDING THIS EQUIPMENT, SEE THE GENERAL EQUIPMENT SAFETY BOOKLET (77-5300).

WARNING

When using Binks equipment with Methyl Ethyl Ketone Peroxide in Plasticizer OBSERVE the following precautions

CORROSIVE TO THE EYES – MAY CAUSE BLINDNESS. MAY BE FATAL IF SWALLOWED. STRONG IRRITANT. CONTAMINATION OR HEAT MAY LEAD TO FIRE OR EXPLOSIVE DECOMPOSITION. COMBUSTIBLE.



Do not handle or use until safety precautions concerning Methyl Ethyl Ketone Peroxides in the Manufacturer's literature have been read and understood.

Contact with foreign materials, especially strong mineral acids, metals (including certain equipment and containers) or metal salts, or exposure to heat above 135° F (57° C) may lead to violent decomposition, releasing flammable vapors which may self-ignite.

Do not get into eyes or on skin or clothing. Wear eye and skin protection when handling. Avoid breathing mist. Use with adequate ventilation. Store only in the original closed container. Wash hands thoroughly after handling. Protect from direct sunlight, heat, sparks and other sources of ignition. Prevent contamination with foreign materials. Do not add to hot materials.

FIRST AID
EYES

Wash immediately (seconds count) with water and continue washing for at least 15 minutes. Obtain medical attention.

SKIN

Wash with soap and water. Remove contaminated clothes and shoes and again wash thoroughly with soap and water.

SWALLOWING

Administer large quantities of milk or water. Obtain immediate medical attention for lavage.

To maintain the chemical activity store below 100° F (38° C).

In case of fire, use water spray, foam or dry chemical.

In case of spill or leak, absorb or blend with inert, non-combustible material. Put in suitable container. Dispose of immediately in accordance with federal, state and local regulations.

Do not reuse container as some of the original hazardous contents may still be present.

Follow the above precautions in handling.

Model 7N PARTS LIST
(When ordering, please specify Part No.)

| ITEM NO. | PART NO. | DESCRIPTION | QTY. | ITEM NO. | PART NO. | DESCRIPTION | QTY. |
|----------|-------------|--------------------------------------|------|----------|-----------|--------------------------------------|------|
| 1 | ★†† | AIR NOZZLE | 1 | 25 | 54-753 | TRIGGER ASSEMBLY | 1 |
| 2 | 20-5052 ● ■ | "O" RING | 1 | 26 | 54-2418 ● | AIR VALVE GASKET | 1 |
| 3 | ★ | FLUID NOZZLE | 1 | 27 | 54-1964 ● | AIR VALVE SPRING | 1 |
| 4 | 20-3600 ● | GASKET | 1 | 28 | 102-2615 | AIR VALVE ASSEMBLY. | 1 |
| 5 | 54-1293 | GUN HEAD. | 1 | 29 | 54-744 ● | AIR VALVE STEM | 1 |
| 6 | 101-5254 | SPRING | 1 | 30 | 54-751 | AIR VALVE BODY. | 1 |
| 7 | 20-1544 | BALL, 5/16" dia | 1 | 31 | 54-2419 ● | AIR VALVE PACKING | 1 |
| 8 | 102-513 | SCREW | 1 | 32 | 54-2417 | AIR VALVE PACKING NUT. | 1 |
| 9 | 54-759 | TRIGGER SCREW | 1 | 33 | 54-1241 | SLEEVE ASSEMBLY. | 1 |
| 10 | 54-760 | TRIGGER STUD. | 1 | 34 | 54-718 | SLEEVE | 1 |
| 11 | 102-916 | BODY PLUG | 1 | 35 | 54-721 | WIPER CUP RETAINER. | 1 |
| 12 | 54-723 ● | "O" RING | 1 | 36 | 54-722 ● | WIPER CUP. | 2 |
| 13 | 102-275 | FLUID CONTROL HOUSING. | 1 | 37 | 2-28 ● | NEEDLE PACKING | 1 |
| 16 | ★★ | FLUID NEEDLE VALVE ASSEMBLY. | 1 | 38 | 54-1407 | NEEDLE PACKING NUT | 1 |
| 17 | 54-724 | FLUID CONTROL ASSEMBLY | 1 | 39 | 54-2524 | RING | 1 |
| 18 | 54-725 | FLUID CONTROL SCREW | 1 | 40 | 54-2527 | SEAL | 1 |
| 19 | 54-728 ● | FLUID CONTROL SPRING. | 1 | 41 | 54-3009 | BASE. | 1 |
| 20 | 54-727 | FLUID CONTROL RING. | 1 | | 73-165 | WRENCH (Not Shown) | 1 |
| 21 | 54-726 | FLUID CONTROL | 1 | | OMX-88 | CLEANING BRUSH (Not Shown) | 1 |
| 22 | 102-264 | GUN BODY. | 1 | | | | |
| 23 | 54-1838 | AIR CONNECTION | 1 | | | | |
| 24 | 54-2416 | PLUG ASSEMBLY | 1 | | | | |

- NOTE:** See Page 6 for Model 102-2138 Flush Valve Assembly.
 ★ When ordering, please specify Part Number stamped on Nozzle.
 ★★ When ordering, please specify Gun model and Part Number stamped on Needle Stem.
 ● Parts also available in Spare Parts Kit 106-1061. Kit not furnished, please order separately.
 †† Use only "Blue Ring" Nozzles and Bases which have special Seal Groove.
 ■ Included with Item 1 and Item 41.

| NOZZLE CHART for Binks Model 7N AIR/CATALYST SPRAY GUN | | | | | | | | | |
|--|--------------|----------------------|---------------------------------|-----------------|-----------------------------|--|------|------|------------|
| FLUID TYPE (VISCOSITY) | NOZZLES | | FLUID NOZZLE ORIFICE SIZE (In.) | AIR NOZZLE TYPE | MAX. PATTERN AT 8" (Inches) | AIR REQUIREMENTS (CFM) AT INDICATED P.S.I. | | | NEEDLE NO. |
| | FLUID x | BLUE RING AIR NOZZLE | | | | 30 | 50 | 70 | |
| Medium to Heavy Cream-Like (Over 75 CPS) (Over 28 Sec. Ford 4) | 68SS x A68PB | | .110 | PE | 12 | 9.5 | 14.1 | 19.1 | 39 |
| | 68SS x 302 | | .110 | PI | 8 | | 6.5 | | 39 |

NOTE: All External Mix Nozzles must be the "Blue-Ring" series. This series incorporates an O-Ring Seal between the shoulder of the Fluid Nozzle and the taper of the Air Nozzle (or Air Nozzle Base).

Other fluid nozzles and air nozzles available. Contact Binks technical support for more information.

NOTE

To prevent damage to "O" Ring, Item 2, during assembly of either Internal or External Mix Nozzles, insert "O" Ring into Base, Item 41, or Air Nozzle, Item 1, making sure "O" Ring is well-centered and bottomed in its groove. Hold Gun vertically, Gun Head, Item 5 down, and screw Base or Nozzle into Gun Head Threads.

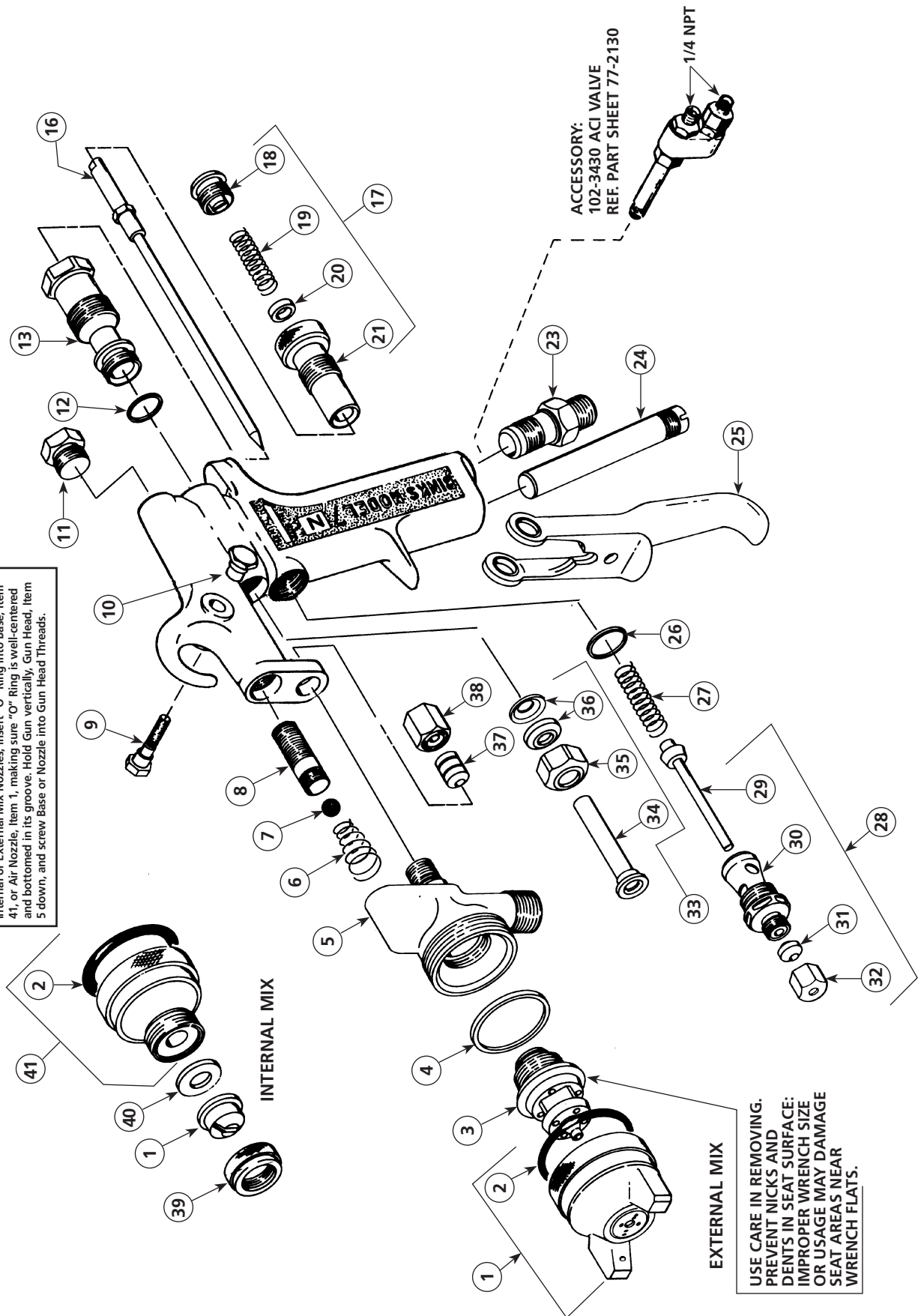

EXTERNAL MIX

USE CARE IN REMOVING.
PREVENT NICKS AND
DENTS IN SEAT SURFACE:
IMPROPER WRENCH SIZE
OR USAGE MAY DAMAGE
SEAT AREAS NEAR
WRENCH FLATS.

Binks 7N Gun Accessories Binks MODEL 102-2138 FLUSH VALVE ASSEMBLY FOR MODEL 7N GUN

INSTALLATION INSTRUCTIONS

1. Remove Air Connection, Item 23, (see Page 4 Parts List) from Gun Handle.
2. Remove Plug Assembly, Item 24, (see Page 4 Parts List) from Gun Handle.
3. Insert Stem, Item 7, (with "O" Ring) of Valve Assembly into Hole from which Plug Assembly was removed.

NOTE: Valve Assembly does not have to be screwed in tightly; the "O" Ring at the top of the Stem provides a complete air seal. Apply a small amount of petroleum jelly to "O" Ring before inserting Stem into Gun Handle.

4. Rotate Valve Assembly so that the flat face of its Body, Item 11, (containing the groove) allows clearance for inserting Air Connection, Item 1, into Hole in base of Gun from which Air Connection (see Step 1 above) was removed.
5. Insert Air Connection, Item 1, and screw up tightly.
6. Hook up Solvent Flush Hose to Valve Assembly at D.M. Nipple, Item 17.
7. Hook up Air Hose to Air Connection, Item 1.

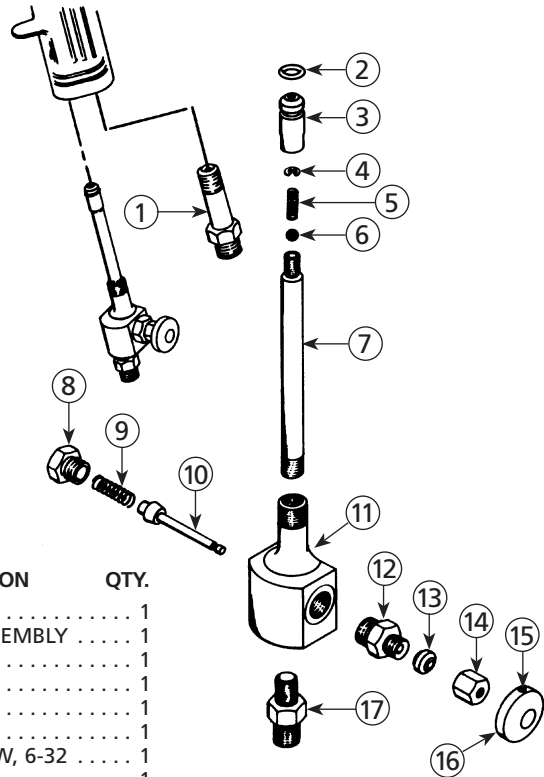

PARTS LIST

(When ordering, please specify Part No.)

| ITEM NO. | PART NO. | DESCRIPTION | QTY. | ITEM NO. | PART NO. | DESCRIPTION | QTY. |
|----------|----------|-----------------------------|------|----------|----------|--|------|
| 1 | 54-2138 | AIR CONNECTION | 1 | 9 | 102-2142 | SPRING | 1 |
| 2 | 20-3847 | "O" RING | 1 | 10 | 102-2135 | STEM ASSEMBLY | 1 |
| 3 | 54-2407 | CAP | 1 | 11 | 102-2132 | BODY | 1 |
| 4 | 20-4544 | "E" RING | 1 | 12 | 102-2133 | GLAND | 1 |
| 5 | 54-2139 | SPRING | 1 | 13 | 54-2419 | PACKING | 1 |
| 6 | 20-2183 | BALL, 3/16 in. dia. | 1 | 14 | 54-2417 | CAP | 1 |
| 7 | 54-2408 | STEM | 1 | 15 | 20-3750 | SET SCREW, 6-32 | 1 |
| 8 | 102-2136 | CAP | 1 | 16 | 102-2137 | BUTTON | 1 |
| | | | | 17 | 72-792 | D.M. NIPPLE, 1/8 NPT x 1/4 NPS. | 1 |

NOTES

WARRANTY POLICY

This product is covered by Carlisle Fluid Technologies' materials and workmanship limited warranty. The use of any parts or accessories, from a source other than Carlisle Fluid Technologies, will void all warranties. Failure to reasonably follow any maintenance guidance provided may invalidate any warranty.

For specific warranty information please contact Carlisle Fluid Technologies.

For technical assistance or to locate an authorized distributor, contact one of our international sales and customer support locations.

| Region | Industrial / Automotive | Automotive Refinishing |
|---------------------------------------|--|--|
| Americas | Tel: 1-800-992-4657 Fax: 1-888-246-5732 | Tel: 1-800-445-3988 Fax: 1-800-445-6643 |
| Europe, Africa, Middle East, India | Tel: +44 (0)1202 571 111 Fax: +44 (0)1202 573 488 | |
| China | Tel: +8621-3373 0108 Fax: +8621-3373 0308 | |
| Japan | Tel: +81 45 785 6421 Fax: +81 45 785 6517 | |
| Australia | Tel: +61 (0) 2 8525 7555 Fax: +61 (0) 2 8525 7575 | |

For the latest information about our products, visit www.carlisleleft.com

Carlisle Fluid Technologies is a global leader in innovative finishing technologies. Carlisle Fluid Technologies reserves the right to modify equipment specifications without prior notice.

BGK™, Binks®, DeVilbiss®, Hosco®, MS®, and Ransburg® are all registered trademarks of Carlisle Fluid Technologies, Inc.

©2020 Carlisle Fluid Technologies, Inc.
All rights reserved.

